

KOMFORT FLOW

ARCHITECTURAL SERIES



- Architecture Grilles
- Louvers
- Linear Bar Grille
- T-Bar Ceiling Diffuser
- Jet Diffuser
- Damper & Filter

COMPANY PROFILE



KOMFORT FLOW S.E. CO. , LTD. , a wholly Thai-owned factory , was established in 1982 by Mr. Santi Taechaaukarakul. We live by a fundamental working philosophy that is dedicated to developing and manufacturing the highest quality products to customers.

The company's reputation, together with the trust and confidence of those with whom we deal, is one of our most vital assets.

Nowadays , we stand in the front line of manufacturer of Air Diffuser , Air grille , Return Air , Damper and Filter under brand “ **KOMFORT FLOW** ”.

In 2006, Komfort Flow S.E. Co., Ltd. was appointed as the exclusive distributor of MUELLER INDUSTRIES, INC., the US leading manufacturer of copper tube, fitting, valves and accessories.

With our skill and experience for decades in HVAC industry, our products have gain trust and reputation from both public and private sector. With diversified demand, we strive to produce the new designed diffusers and grilles in order to satisfy the architecture's aspiration which can be found in this Architecture Series catalogue.

TABLE OF CONTENTS



Four-Way , T Bar Diffuser

Page

1



Flat Plate Diffuser

2

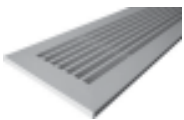

Linear Bar Grille

3-4

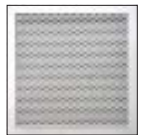

Perforated Grilles

5-6

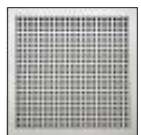

Lattice Grilles

7-8

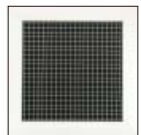

Egg Crate Return Grilles

9-10



Jet Diffuser

11



Supply Air Louver

Page

12-14



Aluminium Louver

15-16



Rain Proof Aluminium Louver

17-18



Diffuser Damper

19



Butterfly Damper

20



Galvanized Steel Duct Damper

21-22



Air Filter

23

Four Way T-Bar Diffuser **Model : 4-PFR**



Fig.1 shows Model 4-PFR

Product Features

Komfort Flow Four Way T-Bar Diffuser (called “Model 4-PFR”) are available for air distribution, return air and architectural application.

Komfort Flow 4-PFR are composed of the removable face. By using sheet metal spring pin, it's easy to remove for cleaning and maintenance.

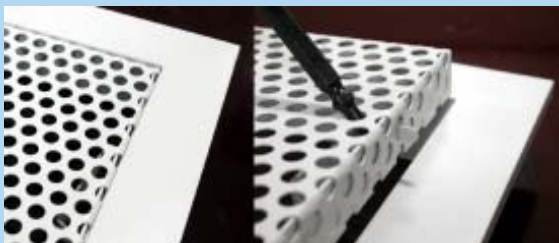

Fig.2 shows how to remove the Perforate face

Material and Finishing

The frame and the hood are constructed from aluminum. Perforate face are constructed from Steel. Optional gauge material are available on request. Komfort Flow 4-PFR are finished with the powder coating in white color. The custom color is upon request.

Perforate Face

Perforated face with 1/4” diameter holes on 3/8” center to center

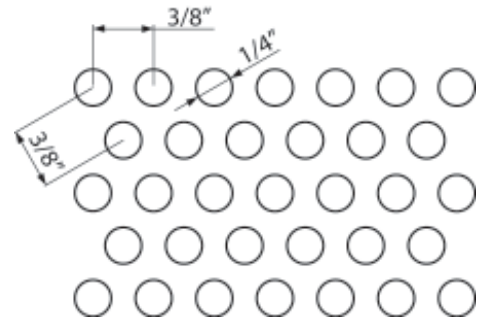

Fig.3 shows pattern of Perforate face

Section and Air Flow Pattern

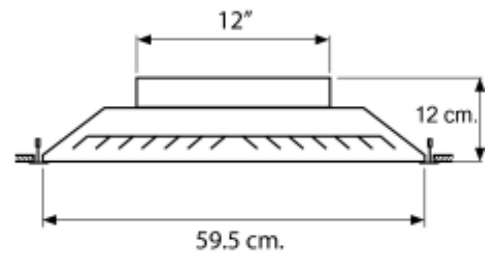

Fig.4 shows Section

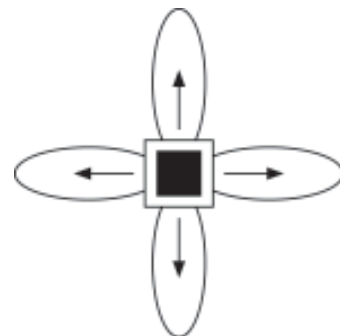

Fig.5 shows Air Flow Pattern (Plan View)



Fig.6 shows Air Flow Pattern (Elevation)

Performance Data

Neck Velocity (FPM)	300	400	500	600	700	800	1000	1200	1400
Velocity Pressure (in.wg.)	0.006	0.01	0.016	0.022	0.031	0.04	0.062	0.09	0.122
Air Flow (CFM)	236	314	393	471	550	628	785	942	1100
Total Pressure (in.wg.)	0.023	0.041	0.064	0.093	0.126	0.165	0.258	0.371	0.505
NC (Noise Criteria)	-	15	22	28	33	37	45	51	56
Throw (Ft)	6	8	10	12	14	15	16	18	19

Flat Plate Diffuser

Model : FPD



Fig.1 shows Model FPD

Product Features

FPD model can maintain 360 Degree radial horizontal air pattern even at low air volumes. Suitable for air distribution with VAV system, and recommended for architectural application.

Komfort Flow Flat Plate Diffuser are composed of the removable flat plate face. By using snap-in pin(See Figure 2), it's easy to remove for cleaning or maintenance.

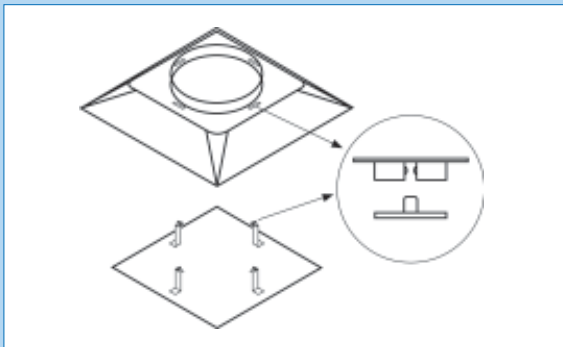

Fig.2 shows "Snap-In"Core

Material

The housing and flat plate face are constructed from aluminum.

The face panel constructed from 1.5 mm aluminum sheet. All borders are folded for the solid construction.

Optional gauge material available on request.

Finishing

Komfort Flow Flat Plate Diffuser are finished with the powder coating in white color. The custom color is upon request.

Section Details

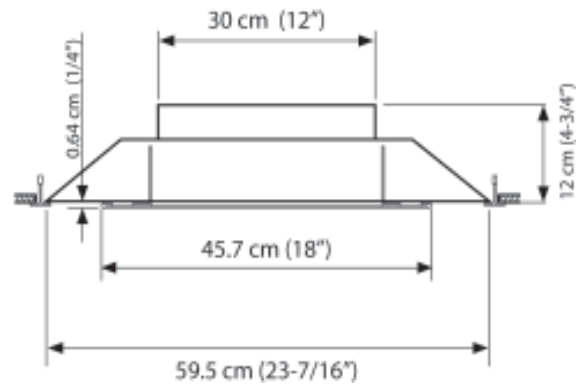

Installation Details

1. Lay-in on 60 cm x 60 cm T-Bar Grid
2. Using flexible duct connecting at the neck of the diffuser.
3. Flexible Duct Size = 12"
4. Use the round transition duct to reduce or increase duct size.

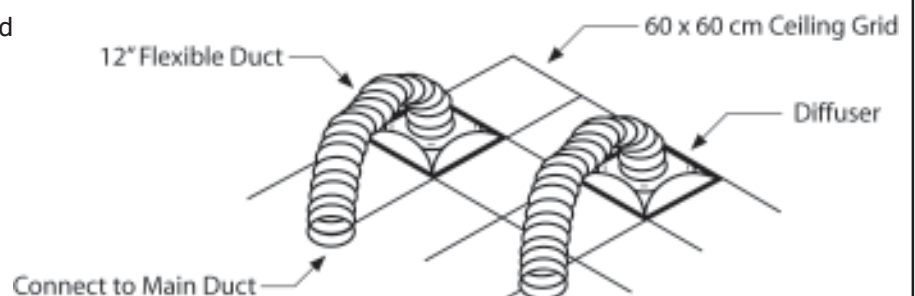

Linear Bar Grilles **Model : LBG**

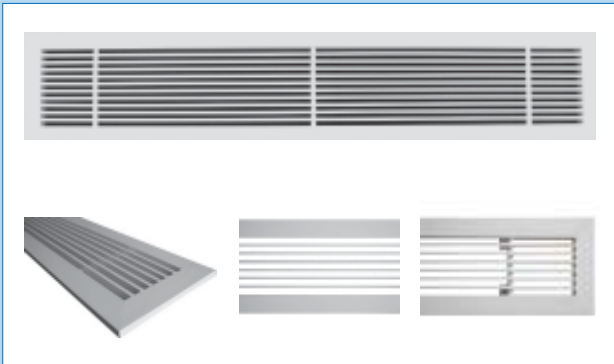

Fig.1 shows Model LBG with 30 mm. standard border

Product Features

Komfort Flow Four Way Linear Bar Grilles are available for air distribution, return air and architectural application.

LBG Model is recommended for ceiling and floor application.

Ceiling Application

LBG is normally installed in the public area such as Lobby and Corridor.

Floor Application

LBG can be installed in computer room and access floor.

Material & Finishing

Komfort Flow Linear Bar Grilles are built with high grade and heavy duty aluminum construction finishing with the powder coating in white. Core bar are supplied parallel to the long dimension. The custom color is upon request.

Available Cores and Frames

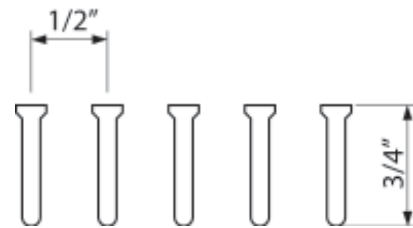

Fig.2 shows "0 Degree Deflection"

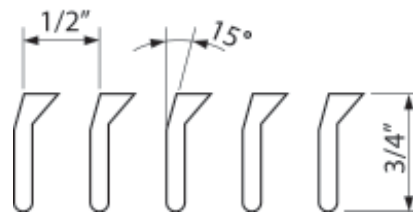

Fig.3 shows "15 Degree Deflection"

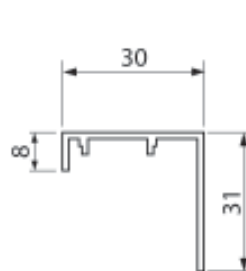

Fig.4 CeilingFrame

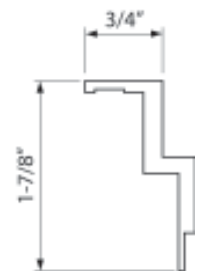

Fig.5 Floor Frame

Ceiling Frame

- Flat frame with 30 mm. border face
- Recommend for general application

Floor Frame

- Very thick extruded aluminum.
- Recommend for floor application

Corner Module

Corner module are available for all series of linear bar grilles. All modules are constructed from extruded aluminum. The standard module are shown below.

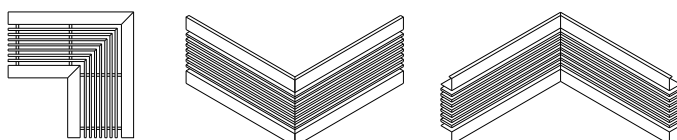

Corner

Wall Inside

Wall Outside

Installation Details

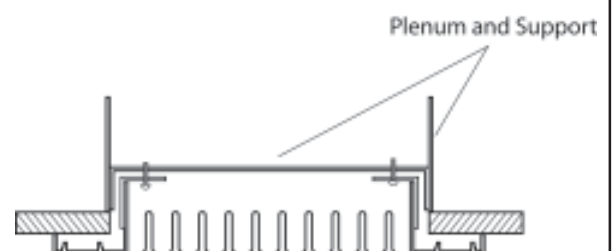

Plenum and Support

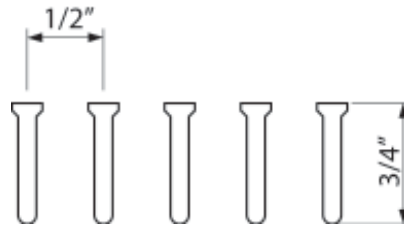

0 Degree Deflection

Size	Static Pressure (in.wg.)	0.01	0.022	0.04	0.063	0.089	0.121	0.159	0.202	0.25
1 1/2"	Flow CFM/Ft.	12	18	24	30	36	42	48	54	60
	NC	-	-	-	-	18	24	28	31	34
	Throw (ft.) C - F	1-4	2-7	4-9	7-12	9-13	11-16	12-17	14-19	16-21
2"	Flow CFM/Ft.	20	29	39	49	59	69	79	89	98
	NC	-	-	-	-	21	25	29	33	36
	Throw (ft.) C - F	1-5	4-9	7-11	9-14	11-16	14-19	16-21	17-22	19-25
3"	Flow CFM/Ft.	38	57	76	95	113	132	151	170	190
	NC	-	-	-	20	25	30	33	36	40
	Throw (ft.) C - F	2-7	7-11	10-14	13-17	16-21	19-24	22-27	24-31	26-34
4"	Flow CFM/Ft.	54	81	108	135	162	189	216	243	270
	NC	-	-	-	21	26	31	34	38	41
	Throw (ft.) C - F	3-8	9-13	13-17	16-21	20-25	23-28	25-30	28-35	31-38
5"	Flow CFM/Ft.	72	108	144	180	216	252	289	324	360
	NC	-	-	17	23	28	33	37	40	43
	Throw (ft.) C - F	4-10	10-14	15-19	18-22	22-27	25-31	27-33	30-37	34-41
6"	Flow CFM/Ft.	90	135	180	225	270	314	360	404	450
	NC	-	-	17	24	30	34	38	41	45
	Throw (ft.) C - F	5-11	10-16	15-20	19-24	23-29	25-33	29-35	31-40	36-44

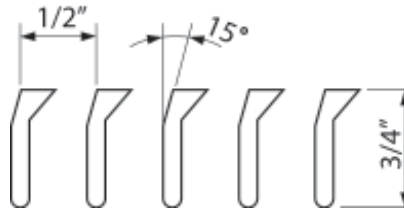

15 Degree Deflection

Size	Static Pressure (in.wg.)	0.01	0.026	0.048	0.076	0.107	0.145	0.191	0.242	0.3
1 1/2"	Flow CFM/Ft.	13	19	26	32	39	45	51	58	64
	NC	-	-	19	25	31	36	40	43	46
	Throw (ft.) C - F	1-4	3-7	5-10	7-12	9-14	11-16	13-18	15-20	16-22
2"	Flow CFM/Ft.	19	29	39	48	58	67	77	87	96
	NC	-	-	16	23	29	33	37	41	44
	Throw (ft.) C - F	1-5	4-8	7-11	9-14	12-17	14-19	16-22	18-23	19-25
3"	Flow CFM/Ft.	34	51	68	85	102	119	136	152	170
	NC	-	-	16	23	29	34	38	41	45
	Throw (ft.) C - F	2-6	6-10	10-14	13-17	16-20	19-24	21-27	24-30	25-33
4"	Flow CFM/Ft.	50	75	100	125	150	175	200	225	250
	NC	-	-	19	25	31	35	40	44	47
	Throw (ft.) C - F	3-8	9-13	13-17	16-20	20-24	22-28	25-30	27-35	30-37
5"	Flow CFM/Ft.	66	99	132	165	198	231	264	297	330
	NC	-	-	20	27	33	38	42	46	48
	Throw (ft.) C - F	4-11	10-15	14-18	18-22	21-29	24-30	27-32	30-35	32-38
6"	Flow CFM/Ft.	84	126	168	210	252	294	336	378	420
	NC	-	-	22	29	35	40	43	47	50
	Throw (ft.) C - F	5-12	10-16	15-21	19-24	23-28	25-31	28-34	31-37	35-41

C = Ceiling , F = Floor

Perforated Grille **Model : PFR**

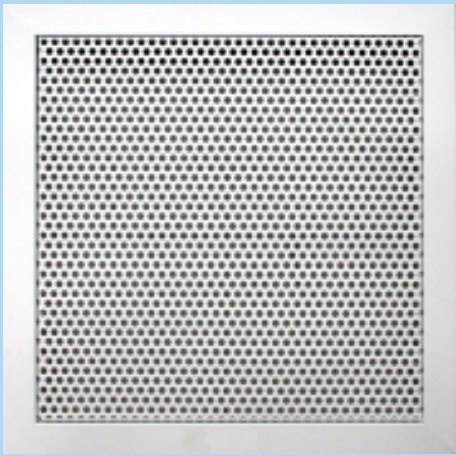

Fig.1 shows Model PFR

Product Features

Komfort Flow PFR Perforated Grilles are available for air distribution, return air, and architectural application. These can be made in a choices of steel or aluminum to suit your desire application.

PFR Model is composed of the removable core. By using sheet metal spring pin, it's easy to remove for cleaning or maintenance.

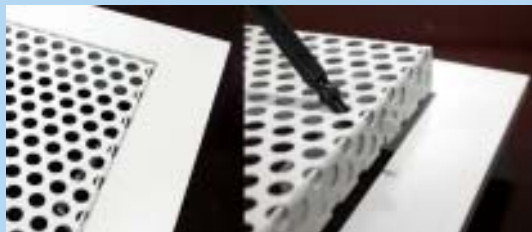

Fig.2 show how to remove the core

Material

The frames are constructed from extruded aluminum with choice of steel or aluminum core.

Optional gauge material available on Request.

Finishing

Komfort Flow Perforated Grilles are finished with the powder coating in white color. The custom color is upon request.

Grilles

Perforated screen with 1/4" diameter holes on 3/8" center to center

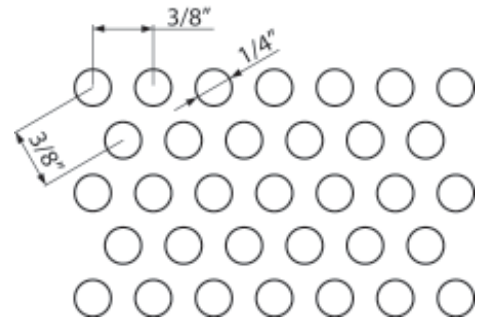

Section Details

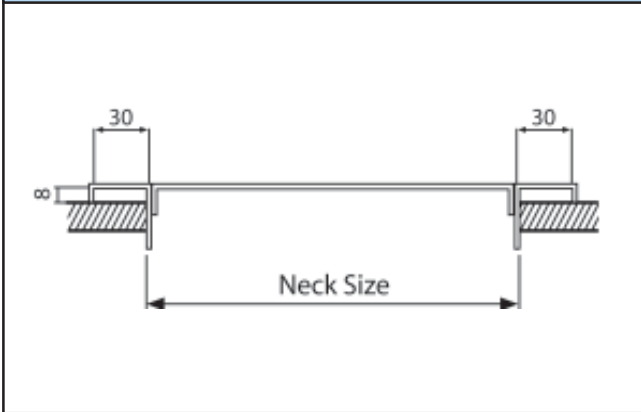

Installation Details

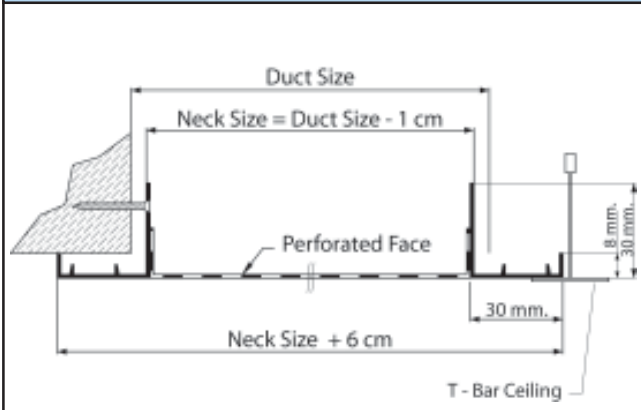

Core Area Sq. Ft.	Nominal Size (inch)	Core Velocity	NC 20							30										
			200		300		400		500		600		700		800		900		1000	
			Velocity	Pressur	0.002	0.006	0.010	0.016	0.022	0.031	0.040	0.050	0.062	0.071	0.082	0.093	0.104	0.115	0.126	0.137
Negative SP			0.019	0.043	0.076	0.118	0.171	0.232	0.303	0.384	0.474									
0.15	6 x 5	CFM	30	45	60	75	90	105	120	135	150									
	7 x 4	NC	--	--	--	20	25	29	33	36	39									
0.18	6 x 6	CFM	36	54	72	90	108	126	144	162	180									
	8 x 4	NC	--	--	--	20	25	29	33	36	39									
0.22	7 x 6	CFM	44	66	88	110	132	154	176	198	220									
	10 x 4	NC	--	--	--	20	25	29	33	36	39									
0.26	6 x 6	CFM	52	78	104	130	156	182	208	234	260									
	12 x 4	NC	--	--	--	20	25	29	33	36	39									
0.30	14 x 4	CFM	60	90	120	150	180	210	240	270	300									
		NC	--	--	--	20	25	29	33	36	39									
0.34	10 x 6	CFM	68	102	136	170	204	238	272	306	340									
	16 x 4	NC	--	--	--	20	25	29	33	36	39									
0.39	8 x 8	CFM	78	117	156	195	234	273	312	351	390									
	14 x 5	NC	--	--	--	20	25	29	33	36	39									
0.46	20 x 4	CFM	92	138	184	230	276	322	368	414	460									
	16 x 5	NC	--	--	--	20	25	29	33	36	39									
0.52	24 x 4	CFM	104	156	208	260	312	364	416	468	520									
	18 x 5	NC	--	--	--	20	25	29	33	36	39									
0.60	28 x 4	CFM	120	180	240	300	360	420	480	540	600									
	20 x 5	NC	--	--	--	20	25	29	33	36	39									
0.69	30 x 4	CFM	138	207	276	345	414	483	552	621	690									
	24 x 5	NC	--	--	--	20	25	29	33	36	39									
0.81	36 x 4	CFM	162	243	324	405	486	567	648	729	810									
	28 x 5	NC	--	--	--	20	25	29	33	36	39									
0.90	40 x 4	CFM	180	270	360	450	540	630	720	810	900									
	30 x 5	NC	--	--	--	20	25	29	33	36	39									
1.07	48 x 4	CFM	214	321	428	535	642	749	856	963	1070									
	36 x 5	NC	--	--	--	20	25	29	33	36	39									
1.18	34 x 6	CFM	236	354	472	590	708	826	944	1062	1180									
	24 x 8	NC	--	--	--	20	25	29	33	36	39									
1.34	60 x 4	CFM	268	402	536	670	804	938	1072	1206	1340									
	48 x 5	NC	--	--	--	20	25	29	33	36	39									
1.60	72 x 4	CFM	320	480	640	800	960	1120	1280	1440	1600									
	30 x 8	NC	--	--	--	20	25	29	33	36	39									
1.80	60 x 5	CFM	360	540	720	900	1080	1260	1440	1620	1800									
	48 x 6	NC	--	--	--	20	25	29	33	36	39									
2.08	72 x 5	CFM	416	624	832	1040	1248	1456	1664	1872	2080									
	60 x 6	NC	--	--	--	20	25	29	33	36	39									
2.45	72 x 6	CFM	490	735	980	1225	1470	1715	1960	2205	2450									
	48 x 8	NC	--	--	--	20	25	29	33	36	39									
2.78	36 x 12	CFM	556	834	1112	1390	1668	1946	2224	2502	2780									
	30 x 14	NC	--	--	--	20	25	29	33	36	39									
3.11	60 x 8	CFM	622	933	1244	1555	1866	2177	2488	2799	3110									
	48 x 10	NC	--	--	--	20	25	29	33	36	39									
3.61	72 x 8	CFM	722	1083	1444	1805	2166	2527	2888	3249	3610									
	60 x 10	NC	--	--	--	20	25	29	33	36	39									
4.29	48 x 14	CFM	858	1287	1716	2145	2574	3003	3432	3861	4290									
	36 x 18	NC	--	--	--	20	25	29	33	36	39									
4.65	72 x 10	CFM	930	1395	1860	2325	2790	3255	3720	4185	4650									
	48 x 16	NC	--	--	--	20	25	29	33	36	39									
5.58	72 x 12	CFM	1116	1674	2232	2790	3348	3906	4468	5022	5580									
	60 x 14	NC	--	--	--	20	25	29	33	36	39									
6.25	72 x 14	CFM	1250	1875	2500	3125	3750	4375	5000	5625	6250									
	60 x 16	NC	--	--	--	20	25	29	33	36	39									

NC 20 30

Notes:

1. All pressures are in inches of water.
2. The NC values are based on a room absorption of 10 dB, re 10-12 watts
3. Blank (--) indicate an NC level below 15.
4. Air flow is in cubic feet per minute, cfm.
5. Neg. SP is negative static pressure.

Lattice Grille **Model : LTG**

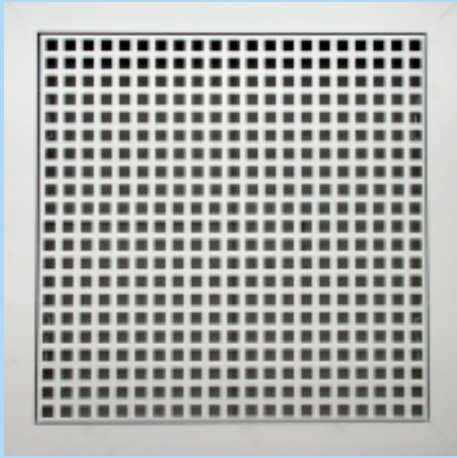

Fig.1 shows Model LTG

Product Features

Komfort Flow LTG Lattice Grilles are available for air distribution, return air, and architectural application. These can be made in a choice of steel or aluminum to suit any application.

Komfort Flow Lattice Grilles are composed of the removable core. By using sheet metal spring pin, it's easy to remove for cleaning or maintenance.

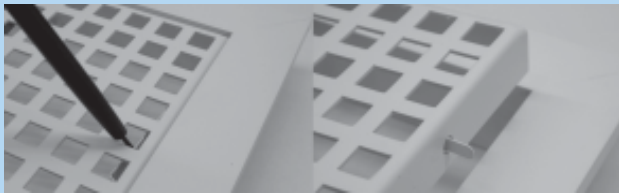

Fig.2 show how to remove the core

Material

The frames are constructed from extruded aluminum and a choice of steel or aluminum core.

Optional gauge material available on Request.

Finishing

Komfort Flow Perforated Grilles are finished with the powder coating in white color. The custom color is upon request.

LTG10

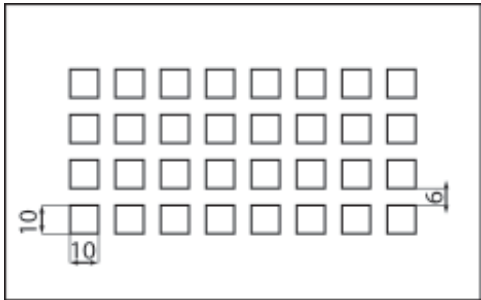

LTG15

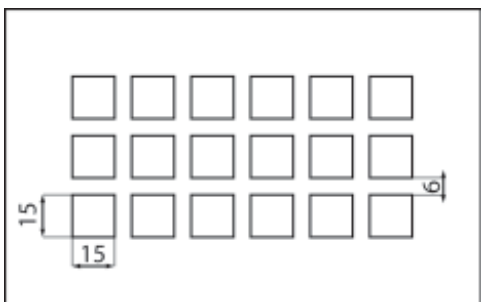

LTG20

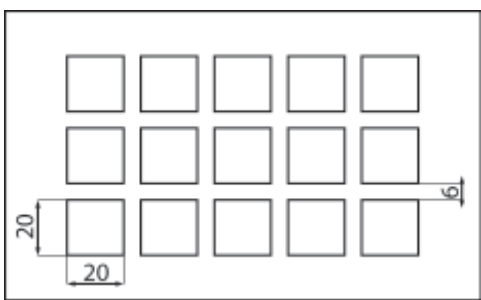

Grilles

10 mm. Square Mesh	LTG 10
15 mm. Square Mesh	LTG 15
20 mm. Square Mesh	LTG 20

Installation Details

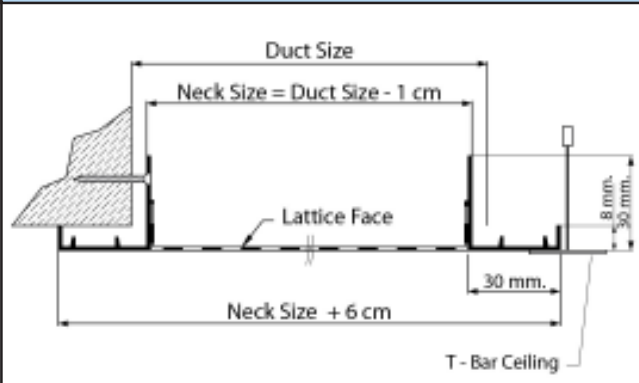

Performance Data

Number of Holes	LTG10 mm.	Number of Holes	LTG10 mm.	Number of Holes	LTG10 mm.	Number of Holes	LTG10 mm.
1	10	21	330	41	650	61	970
2	26	22	346	42	666	62	986
3	42	23	362	43	682	63	1002
4	58	24	378	44	698	64	1018
5	74	25	394	45	714	65	1034
6	90	26	410	46	730	66	1050
7	106	27	426	47	746	67	1066
8	122	28	442	48	762	68	1082
9	138	29	458	49	778	69	1098
10	154	30	474	50	794	70	1114
11	170	31	490	51	810	71	1130
12	186	32	506	52	826	72	1146
13	202	33	522	53	842	73	1162
14	218	34	538	54	858		
15	234	35	554	55	874		
16	250	36	570	56	890		
17	266	37	586	57	906		
18	282	38	602	58	922		
19	298	39	618	59	938		
20	314	40	634	60	954		

Number of Holes	LTG15 mm.	Number of Holes	LTG15 mm.	Number of Holes	LTG15 mm.
1	15	21	435	41	855
2	36	22	456	42	876
3	57	23	477	43	897
4	78	24	498	44	918
5	99	25	519	45	939
6	120	26	540	46	960
7	141	27	561	47	981
8	162	28	582	48	1002
9	183	29	603	49	1023
10	204	30	624	50	1044
11	225	31	645	51	1065
12	246	32	666	52	1086
13	267	33	687	53	1107
14	288	34	708	54	1128
15	309	35	729	55	1149
16	330	36	750		
17	351	37	771		
18	372	38	792		
19	393	39	813		
20	414	40	834		

Number of Holes	LTG20 mm.	Number of Holes	LTG20 mm.	Number of Holes	LTG20 mm.	Number of Holes	LTG20 mm.
1	20	11	280	21	540	31	800
2	46	12	306	22	566	32	826
3	72	13	332	23	592	33	852
4	98	14	358	24	618	34	878
5	124	15	384	25	644	35	904
6	150	16	410	26	670	36	930
7	176	17	436	27	696	37	956
8	202	18	462	28	722	38	982
9	228	19	488	29	748	39	1008
10	254	20	514	30	774	40	1034
11	280	21	540	31	800	41	1060
12	306	22	566	32	826	42	1086
13	332	23	592	33	852	43	1112
14	358	24	618	34	878	44	1138
15	384	25	644	35	904	45	1164

Sound

$$NC = 14 \text{ LOG } A + 84 \text{ LOG } V - 218$$

$$A = \text{Free area, Ft}^2$$

$$V = \text{Air Flow, CFM / Free Area, Ft}^2$$

NC based on 10dB room absorption.

Negative Static Pressure

$$S.P. = 1.36 (V/4005)^2$$

$$V = \text{Air Flow, CFM / Free Area, Ft}^2$$

$$S.P. = \text{Static Pressure Drop, inches w.g.}$$

Free Area

$$F.A. = \text{Number of holes} \times \begin{matrix} 0.0011 \text{ (LTG10)} \\ 0.0024 \text{ (LTG15)} \\ 0.0043 \text{ (LTG20)} \end{matrix}$$

Example Calculation of LTG10 with the neck area of 40 x 50 cm. at 400 cfm.

Number of holes : Horizontal Length 40 cm. = 25 holes
 Vertical Length 50 cm. = 32 holes

Therefore, total number of holes = 25 x 32 = 800 holes
 F.A. = 800 x 0.0011 = 0.88 Ft²

Egg Crate Return Grille

Model : EGC



Fig.1 shows Model EGC

Product Features

Komfort Flow EGC Egg Crate Return Grille are available for air distribution, return air, and architectural application. It is made of aluminum. There are two models :-

- Counter Sunk Screw Holes (Model EGC)
- Hidden Screw Holes (Model EGC-R)

Characteristics

- High Grade Aluminum Construction
- Large Free Area Core
- Low Pressure Drop
- Low NC Level
- Ideal for Pressurized ceiling return
- Powder Coating Finishing
- Matches to Modern Interior and Modern Architecture

Material

The frame are constructed from extruded aluminum and the frame size is 1 1/4". Size of Aluminum core is 1/2" x 1/2" x 1/2"

Finishing

Komfort Flow Egg Crate Return Grilles are finished with the powder coating in white or Matt Black color.

Optional Features

- Opposed blade volume damper available in black color or natural anodized aluminum finish
- Wire mesh

Model EGC is easy to remove the core (EGC-R) for maintenance with Spring-Pin Lock



Suitable for the Laminar Flow pattern in the Cleanroom.

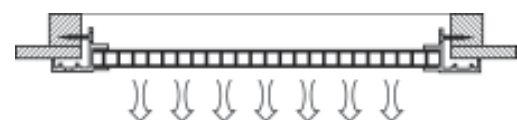

Section and Installation Details

Model : EGC

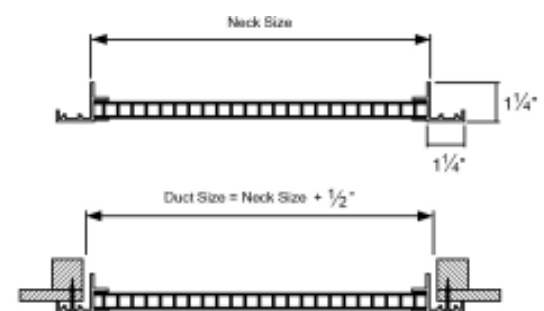

Model : EGC-R

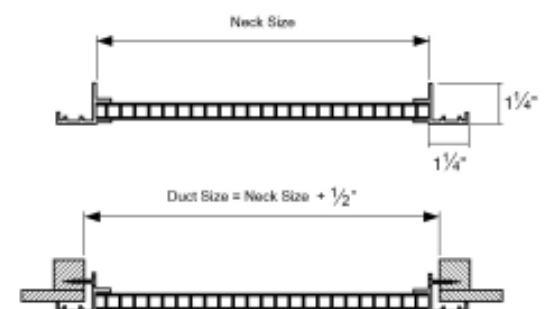

Performance Data

Core Area Sq. Feet	Duct size		Core Velocity Velocity Pressure Negative SP	300	400	500	600	700	800	NC 20		NC 30	
				0.006	0.01	0.016	0.022	0.031	0.04	1000	1200	1400	1500
				0.013	0.021	0.034	0.047	0.066	0.085	0.062	0.09	0.122	0.14
										0.132	0.192	0.26	0.298
0.15	7x4		CFM	44	59	73	88	106	120	152	181	210	223
	6x5		NC	-	-	-	-	-	-	22	29	35	36
0.18	8x4	6x6	CFM	54	71	92	108	126	144	181	215	253	271
	7x5		NC	-	-	-	-	-	-	20	27	36	39
0.22	10x4	7x6	CFM	66	87	111	131	154	175	220	263	307	330
	8x5		NC	-	-	-	-	-	-	25	30	35	37
0.26	12x4	8x6	CFM	76	105	131	157	180	206	260	315	365	390
	10x5		NC	-	-	-	-	-	16	25	32	37	40
0.3	14x4		CFM	90	120	151	182	210	241	300	359	419	450
			NC	-	-	-	-	-	17	23	32	38	39
0.34	16x4	10x6	CFM	101	134	172	203	237	270	340	407	475	510
	12x5		NC	-	-	-	-	-	18	26	33	38	40
0.39	18x4	12x6	CFM	115	159	193	234	275	313	390	467	544	585
	14x5	8x8	NC	-	-	-	-	-	15	25	32	38	40
0.46	20x4	14x6	CFM	137	185	231	277	321	367	460	554	644	690
	16x5	10x8	NC	-	-	-	-	-	20	28	34	38	40
0.52	24x4	16x6	CFM	158	207	260	314	365	417	520	624	730	780
	18x5		NC	-	-	-	-	-	20	28	34	31	42
0.6	28x4	18x6	10x10	CFM	183	241	301	360	420	602	718	839	901
	20x5	12x8		NC	-	-	-	-	20	28	35	40	43
0.69	30x4	20x6	12x10	CFM	208	276	346	413	483	689	827	965	1037
	24x5	14x8		NC	-	-	-	-	20	27	33	40	44
0.81	36x4	22x6	14x10	CFM	243	322	404	487	567	811	973	1135	1216
	28x5	16x8		NC	-	-	-	-	20	29	36	42	44
0.9	40x4	26x6	16x10	CFM	271	361	449	540	541	719	899	1079	1261
	30x5	18x8	12x12	NC	-	-	-	-	16	20	30	31	42
1.07	48x4	30x6	14x12	CFM	322	429	537	643	750	857	1069	1283	1497
	36x5	18x10		NC	-	-	-	-	17	22	22	37	43
1.18	34x6	20x10	14x14	CFM	352	371	589	705	829	945	1181	1414	1654
	24x8	16x12		NC	-	-	-	-	16	23	30	37	44
1.34	60x4	36x6	16x14	CFM	404	536	670	805	940	1073	1341	1610	1879
	48x5	18x12		NC	-	-	-	-	19	22	33	39	45
1.6	72x4	24x10	18x14	CFM	482	644	802	962	1122	1281	1600	1920	2240
	30x8	22x12	16x16	NC	-	-	-	-	19	23	32	38	45
1.8	60x5	36x8	24x12	18x16	CFM	541	721	902	1083	1261	1441	1801	2161
	48x6	30x10	20x14		NC	-	-	-	-	19	24	32	39
2.08	72x5	40x8	30x12	20x16	CFM	625	833	1041	1249	1457	1665	2081	2497
	60x6	36x10	24x14	18x18	NC	-	-	-	-	19	24	33	38
2.45	72x6	32x12	24x16		CFM	734	981	1224	1472	1717	1959	2454	2939
	48x8	26x14	20x18		NC	-	-	-	-	20	23	32	38
2.78	36x12	26x16	22x20		CFM	832	1111	1391	1667	1945	2223	2781	3335
	30x14	24x18			NC	-	-	-	-	21	23	31	39
3.11	60x8	40x12	30x16	24x20	CFM	933	1243	1556	1856	2176	2487	3000	3731
	48x10	36x14	26x18		NC	-	-	-	-	20	25	33	40
3.61	72x8	48x12	30x18		CFM	1083	1441	1803	2166	2527	2889	3611	4333
	60x10	36x16	24x24		NC	-	-	-	-	22	27	35	42
4.29	48x14	32x20			CFM	1286	1717	2144	2573	3004	3433	4290	5147
	36x18	28x24			NC	-	-	-	13	19	25	31	42
4.65	72x10	36x20			CFM	1395	1860	2325	2791	3256	3721	4652	5581
	48x16	30x24			NC	-	-	-	17	23	28	36	43
5.58	72x12	48x29			CFM	1675	2233	2791	3349	3907	4465	5581	6697
	60x14	36x24			NC	-	-	-	17	23	29	37	44
6.25	72x14	48x20			CFM	1876	2501	3126	3751	4376	5000	6250	7500
	60x16	30x30			NC	-	-	-	18	24	29	37	44

Notes:

1. All pressures are in inches of water.
2. Blanks indicate and NC level <15 dB.

NC 20 NC 30 NC 40 NC 50

Jet Diffuser **Model : JD**



Fig.1 shows Model JD

Product Features

Jet nozzles are used for preference where the supply air from the diffuser has to travel a large distance to the occupied zone. This is the case in large rooms (halls, assembly rooms etc.), particularly when the distribution of air via ceiling diffusers is not possible or not practical. Here jet diffusers are arranged in the side wall areas. The direction of the air stream from the type jet nozzle can be easily adjusted manually to suit particular on site conditions. Also the pivoting movement can be adjusted within the range of +/- 30 degree.

Material and Finishing

The frame and adjustable nozzle made from aluminum and finishing with the powder coating, (Standard Color in White)

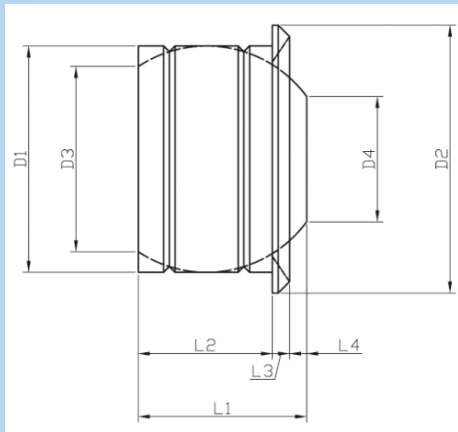

Fig.2 Section Detail

SIZE	D1	D2	D3	D4	L1	L2	L3	L4
6"	150	195	100	65	150	115	28	7
8"	203	265	150	105	150	115	28	7
10"	254	310	195	130	210	170	28	12
12"	320	380	250	180	248	195	28	25
16"	397	470	325	220	295	235	30	30
18"	450	520	370	275	305	235	40	30
20"	492	580	415	285	346	245	40	61

Performance Data

SIZE	Duct Velocity (FPM)	200	300	400	500	600	700	800
	Velocity Pressure (IN WG)	0.002	0.006	0.01	0.016	0.022	0.031	0.04
6"	Flow Rate (CFM)	135	203	271	339	406	474	542
	Total Pressure (IN WG)	0.076	0.171	0.303	0.474	0.683	0.929	1.214
	Static Pressure (IN WG)	0.074	0.165	0.293	0.458	0.661	0.898	1.174
	NC Level	-	19	28	35	40	45	50
	Throw (FT)	15	17	20	23	25	27	29
	8"	Flow Rate (CFM)	196	294	392	490	588	685
Total Pressure (IN WG)		0.056	0.127	0.226	0.353	0.508	0.691	0.903
Static Pressure (IN WG)		0.054	0.121	0.216	0.337	0.486	0.66	0.863
NC Level		-	17	25	31	36	40	44
Throw (FT)		17	21	25	27	30	32	34
10"		Flow Rate (CFM)	267	401	535	668	802	936
	Total Pressure (IN WG)	0.037	0.084	0.149	0.232	0.334	0.455	0.594
	Static Pressure (IN WG)	-	-	18	25	30	35	39
	NC Level	0.035	0.078	0.139	0.216	0.312	0.424	0.554
	Throw (FT)	20	25	29	32	35	38	41
	12"	Flow Rate (CFM)	350	525	700	875	1050	1225
Total Pressure (IN WG)		0.033	0.075	0.132	0.207	0.298	0.406	0.53
Static Pressure (IN WG)		0.031	0.069	0.122	0.191	0.276	0.375	0.49
NC Level		-	11	16	26	31	35	39
Throw (FT)		23	28	33	36	40	43	47
16"		Flow Rate (CFM)	548	823	1097	1371	1645	1919
	Total Pressure (IN WG)	0.022	0.052	0.092	0.118	0.215	0.293	0.362
	Static Pressure (IN WG)	0.020	0.046	0.082	0.102	0.193	0.262	0.322
	NC Level	-	11	17	28	33	36	40
	Throw (FT)	29	35	40	44	48	52	55
	18"	Flow Rate (CFM)	665	997	1329	1662	1994	2326
Total Pressure (IN WG)		0.022	0.051	0.090	0.114	0.211	0.292	0.359
Static Pressure (IN WG)		0.020	0.045	0.080	0.098	0.189	0.261	0.319
NC Level		-	12	18	30	34	37	41
Throw (FT)		30	38	42	48	50	54	59
20"		Flow Rate (CFM)	792	1187	1583	1979	2375	2771
	Total Pressure (IN WG)	0.021	0.050	0.088	0.113	0.209	0.291	0.357
	Static Pressure (IN WG)	0.019	0.044	0.078	0.097	0.187	0.260	0.317
	NC Level	-	12	20	32	35	40	42
	Throw (FT)	32	40	45	51	54	56	62

Supply Air Louver **Model : SAL**



Fig.1 shows Model SAL

Product Features

- 2" Blade Spacing
- Single Deflection
- Individually Adjustable
- Air Foil Blades
- Blades Parallel to the Short dimension or Parallel to the Long dimension
- Minimum Size : 4" x 6"
- Maximum Size : 40" x 40"

Material and Finishing

- Extruded Aluminium Border with Extruded Aluminum Blades
- Rubber Bushing
- Stamped corner and welded border
- Countersunk Screw Holes (Standard)
- Optional Opposed Blade Damper
- Anodized Aluminum Finishing

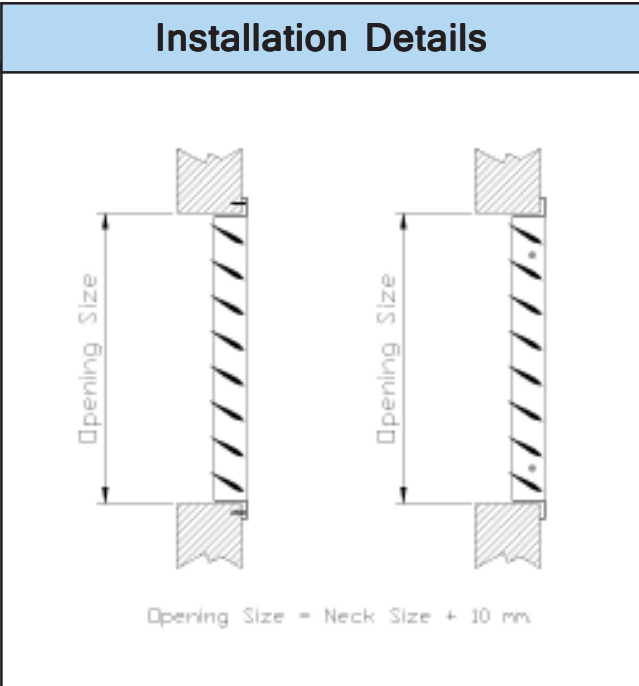
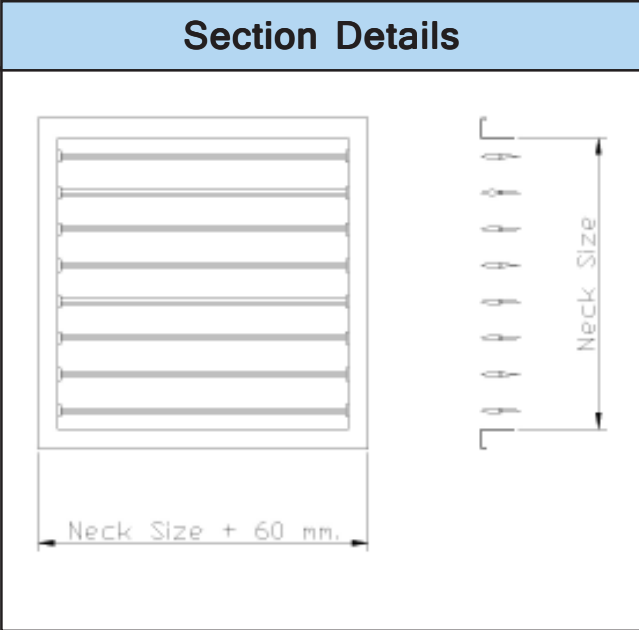

Performance Data

CORE VELOCITY FPM		300	400	500	600	700	800	1000	1200	1400	1600	1800	
SIZE	VELOCITY PRESSURE	0.006	0.01	0.016	0.022	0.031	0.04	0.062	0.09	0.122	0.160	0.202	
	Total	0°	0.012	0.020	0.032	0.044	0.061	0.079	0.123	0.178	0.242	0.317	0.400
		Pressure	15°	0.013	0.021	0.034	0.046	0.065	0.084	0.130	0.189	0.256	0.336
	45°	0.025	0.041	0.066	0.090	0.127	0.164	0.254	0.369	0.500	0.656	0.828	
Ac = 0.15 ft ²	CFM	45	60	75	90	105	120	150	180	210	240	270	
7x4 6x5	NC	-	-	-	-	-	16	24	31	37	42	46	
		0°	4-6-11	5-8-13	7-10-15	8-11-16	9-12-18	10-13-19	12-15-21	13-16-23	14-18-25	15-18-25	16-21-29
	Throw	15°	3-5-10	4-6-10	6-8-12	6-10-13	7-10-14	9-10-15	10-12-17	10-13-18	11-14-20	12-15-21	13-17-23
	Ft.	45°	5-8-13	3-4-7	3-5-8	4-6-9	5-7-9	5-7-10	6-8-10	7-9-11	8-9-12	8-10-13	9-10-14
Ac = 0.22 ft ²	CFM	66	88	110	132	154	176	220	264	308	352	396	
10x4 8x5	NC	-	-	-	-	-	17	25	32	38	43	47	
		0°	4-7-13	7-10-16	8-11-18	8-14-20	10-16-22	12-16-23	15-18-26	16-20-28	18-20-30	19-24-32	20-25-34
	Throw	15°	3-6-10	6-8-13	6-10-14	7-11-16	8-12-17	10-13-18	12-14-21	13-16-22	14-17-25	15-19-26	16-20-28
	Ft.	45°	2-4-7	3-5-9	4-6-10	5-7-10	6-8-10	6-9-11	8-10-12	9-10-14	9-11-15	10-11-16	10-12-17
Ac = 0.30 ft ²	CFM	90	120	150	180	210	240	300	360	420	480	540	
14x14	NC	-	-	-	-	-	18	26	33	38	43	48	
		0°	5-9-16	8-10-19	9-13-21	10-16-23	12-18-25	14-19-25	17-22-29	19-24-32	21-26-35	23-28-38	24-29-40
	Throw	15°	4-7-13	6-9-15	7-10-17	9-13-18	9-14-20	10-14-21	13-17-24	15-19-26	17-21-29	18-22-30	19-23-32
	Ft.	45°	3-4-8	4-6-10	5-7-10	6-8-11	7-9-12	8-10-13	9-10-15	10-11-16	10-12-18	11-13-19	11-14-20
Ac = 0.39 ft ²	CFM	117	156	195	234	273	312	390	468	546	624	702	
18x4 14x5	NC	-	-	-	-	-	18	27	33	39	44	48	
		0°	6-9-18	9-12-22	10-15-24	12-18-27	14-21-29	16-22-30	20-25-34	22-26-38	24-29-40	26-31-43	27-33-46
	Throw	15°	5-7-14	7-10-17	9-12-19	10-14-21	11-17-23	13-17-25	16-20-28	17-21-30	19-23-32	21-25-34	21-27-36
	Ft.	45°	3-5-10	4-6-10	5-8-12	7-10-13	8-10-14	9-11-15	10-12-17	11-13-19	11-14-20	12-15-22	13-16-23
Ac = 0.52 ft ²	CFM	156	208	260	312	364	416	520	624	728	832	936	
24x4 18x5	NC	-	-	-	-	-	19	27	34	40	45	49	
		0°	7-10-22	10-14-25	12-18-28	14-21-30	17-24-33	19-25-35	23-29-39	26-31-43	28-33-47	29-36-49	30-38-52
	Throw	15°	6-9-17	8-11-20	10-14-22	11-17-25	13-19-27	15-20-29	18-23-31	21-25-34	22-27-37	24-29-40	25-30-42
	Ft.	45°	3-5-10	5-7-12	6-9-14	8-10-15	9-11-16	10-12-17	11-14-20	12-15-22	13-17-23	14-18-25	15-19-27
Ac = 0.69 ft ²	CFM	207	276	345	414	483	552	690	828	966	1104	1242	
30x4 24x5	NC	-	-	-	-	-	20	28	35	41	46	50	
		0°	8-12-25	11-16-29	14-21-32	17-25-35	20-28-48	23-29-41	27-32-45	29-36-49	31-38-53	33-41-57	35-43-60
	Throw	15°	6-10-20	10-13-23	11-17-26	13-20-29	16-22-30	18-24-32	21-26-36	23-29-40	15-30-43	27-32-46	29-34-48
	Ft.	45°	4-6-12	6-9-14	7-10-16	9-12-17	10-13-19	11-14-20	13-16-23	14-18-25	15-19-27	17-21-29	18-22-29
Ac = 0.90 ft ²	CFM	270	360	450	540	630	720	900	1080	1260	1440	1620	
40x4 30x5	NC	-	-	-	-	15	20	29	36	41	46	51	
		0°	9-14-29	13-19-32	16-24-37	20-29-40	23-31-43	26-33-46	30-37-52	33-41-57	35-44-60	38-47-60	40-50-68
	Throw	15°	7-11-23	10-15-26	13-19-29	16-23-32	18-25-34	21-27-36	25-29-42	27-32-45	29-35-48	30-37-51	32-40-55
	Ft.	45°	5-8-14	7-10-16	9-12-18	10-14-20	11-15-22	13-16-23	15-19-26	16-20-28	18-22-30	19-23-32	20-25-34

Performance Notes

1. Pressure

All pressures are in inches of water.

2. Throw

Maximum throws are to a terminal velocity of 50 FPM ($V_T = 50$).

Middle throws are to a terminal velocity of 100 FPM ($V_T = 100$).

Minimum throws are to a terminal velocity of 150 FPM ($V_T = 150$).

3. Throw data based on supply air and room air being at isothermal conditions.

4. Sound

The NC values are based on a room absorption of 10dB, re10-12 watts with a single register set at 0° deflection. For deflection settings of 15° and 45°, increase the listed sound levels by 1 and 12 respectively.

Continue

CORE VELOCITY FPM		300	400	500	600	700	800	1000	1200	1400	1600	1800		
SIZE	VELOCITY PRESSURE	0.006	0.01	0.016	0.022	0.031	0.04	0.062	0.09	0.122	0.160	0.202		
	Total Pressure	0°	0.012	0.020	0.032	0.044	0.061	0.079	0.123	0.178	0.242	0.317	0.400	
		15°	0.013	0.021	0.034	0.046	0.065	0.084	0.130	0.189	0.256	0.336	0.424	
		45°	0.025	0.041	0.066	0.090	0.127	0.164	0.254	0.369	0.500	0.656	0.828	
Ac = 1.18 ft ²		CFM	354	472	590	708	826	944	1180	1416	1652	1888	2124	
34x6	24x8	NC	-	-	-	-	16	21	29	36	42	47	51	
20x10	16x12	0°	10-16-32	14-22-38	18-27-42	22-33-46	26-36-50	29-38-53	34-43-59	38-46-64	41-49-69	43-53-74	46-56-79	
14x14	Throw	15°	8-13-26	11-17-30	14-21-33	17-27-36	21-29-40	24-30-43	28-34-48	30-36-51	32-40-55	34-43-59	36-45-63	
		Ft.	45°	5-8-16	8-10-19	10-13-21	11-16-23	12-18-25	14-19-27	17-21-29	19-23-32	20-25-35	22-27-37	23-29-39
Ac = 1.60 ft ²		CFM	480	640	800	960	1120	1280	1600	1920	2240	2560	2880	
72x4	30x8	NC	-	-	-	-	17	22	30	37	43	48	52	
24x10	22x12	0°	12-19-38	17-25-44	21-30-48	16-37-53	29-41-57	32-44-61	40-48-68	44-53-75	47-58-81	50-62-86	53-66-92	
18x14	Throw	15°	10-15-30	13-20-35	17-25-39	21-29-43	24-32-46	27-35-48	32-39-55	35-43-60	37-47-65	40-49-69	43-52-74	
		Ft.	45°	6-10-19	9-12-22	10-15-24	12-19-27	14-21-29	16-22-30	20-25-34	22-27-37	24-29-41	25-30-44	27-33-46
Ac = 2.08 ft ²		CFM	624	832	1040	1248	1456	1664	2080	2496	2912	3328	3744	
72x5	60x6	NC	-	-	-	-	18	23	31	38	43	48	53	
40x8	35x10	0°	13-22-43	19-29-49	25-36-55	29-42-60	33-47-65	38-50-69	46-56-78	49-61-86	53-66-92	57-71-99	61-75-105	
30x12	Throw	15°	10-17-34	15-23-40	20-29-44	23-33-48	27-37-51	30-40-55	36-45-63	40-48-68	43-52-74	46-57-79	48-60-84	
		Ft.	45°	7-10-22	10-14-25	12-18-28	14-21-30	16-24-32	19-25-35	23-28-39	25-30-43	27-33-46	29-35-49	29-38-52
Ac = 2.78 ft ²		CFM	834	1112	1390	1668	1946	2224	2780	3336	3892	4448	5004	
36x12	30x14	NC	-	-	-	-	18	23	32	38	44	49	54	
26x16	24x18	0°	15-25-49	22-32-57	28-40-64	33-48-69	38-54-75	43-58-81	52-65-90	57-71-99	62-77-106	67-83-116	70-88-122	
22x20	Throw	15°	12-20-40	17-26-46	22-32-51	27-38-55	30-44-60	34-47-65	42-51-72	46-57-79	49-62-86	53-67-93	56-70-97	
		Ft.	45°	8-12-25	11-16-29	13-20-31	16-24-35	19-27-38	22-29-40	27-32-45	29-35-49	31-38-53	33-41-58	35-44-61
Ac = 3.61 ft ²		CFM	1083	1444	1805	2166	2527	2888	3610	4332	5054	5776	6498	
72x8	60x10	NC	-	-	-	-	19	24	32	39	45	50	54	
48x12	36x16	0°	17-28-56	25-36-65	30-45-72	36-53-80	42-62-86	48-66-92	60-74-103	66-82-112	71-88-122	76-94-130	82-98-139	
30x18	Throw	15°	13-22-45	20-29-51	25-36-58	29-43-64	33-49-68	39-52-74	48-59-82	52-66-84	57-70-97	57-75-105	66-80-111	
		Ft.	45°	9-13-28	12-18-32	15-22-36	18-27-40	21-30-43	24-33-46	29-37-51	33-41-56	36-44-61	38-48-66	41-49-69
Ac = 4.65 ft ²		CFM	1395	1860	2325	2790	3255	3720	4650	5580	6510	7440	8370	
72x10	48x16	NC	-	-	-	-	20	25	33	40	46	51	55	
36x20	30x24	0°	19-31-64	28-41-74	34-51-83	42-62-90	48-70-98	55-75-105	68-85-117	75-92-128	82-100-139	86-107-148	91-114-156	
		Throw	15°	15-25-51	22-32-59	28-41-67	33-49-72	39-56-78	44-60-84	55-67-93	60-74-103	66-80-111	69-86-119	73-91-124
		Ft.	45°	10-15-31	14-21-37	17-26-41	21-30-46	24-35-49	28-38-52	34-42-58	37-47-64	41-49-69	44-53-74	46-57-78
Ac = 6.25 ft ²		CFM	1875	2500	3125	3750	4375	5000	6250	7500	8750	10000	11250	
72x14	60x16	NC	-	-	-	-	20	25	34	41	46	51	56	
48x20	30x30	0°	31-47-74	31-47-86	40-59-95	48-71-104	55-82-113	64-88-122	80-99-136	87-107-148	93-117-161	101-125-171	106-133-182	
		Throw	15°	17-29-59	24-36-68	32-48-76	38-57-83	44-66-90	51-70-97	64-79-108	70-86-119	74-93-128	81-100-133	86-106-145
		Ft.	45°	11-18-37	16-24-43	20-29-48	24-35-53	28-41-57	32-44-61	40-49-68	44-54-74	47-58-81	50-63-86	53-67-91

5. Blanks (--) indicate an NC level below 15.

6. Deflection

The listed deflection settings refer to horizontal deflection. For a 15° upward deflection, use the room throw rating for a 0° setting and the total pressure for a 15° horizontal setting.

The performance tables are based on units with an opposed blade damper.

Aluminum Louver **Model : AL**



Fig.1 shows Model AL

Product Features

Komfort Flow Aluminium Louver is a ventilation product that allows air to pass through it while keeping out unwanted elements such as water, dirt, and debris.

Standard blade, standard performance offers a clean appearance at a low cost.

Ideal applications include decorative, low air velocity, air exhaust, or special shape louvers.

Application of any louver involves selecting an airflow velocity through the louver free area (free area velocity in fpm) that produces an acceptable pressure drop and for intake applications minimizes carry-over of normally occurring rain.

Section Detail

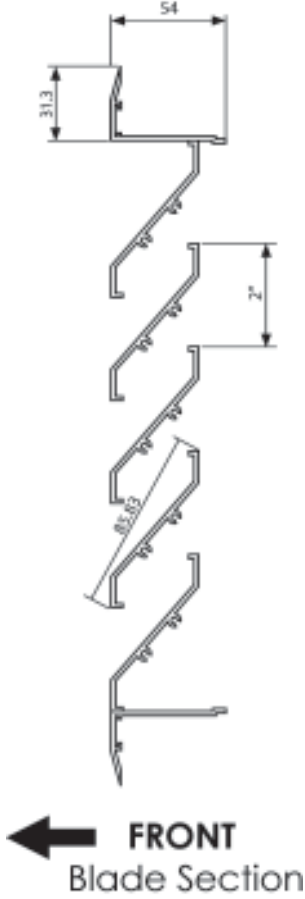

Pressure Drop - Air Intake

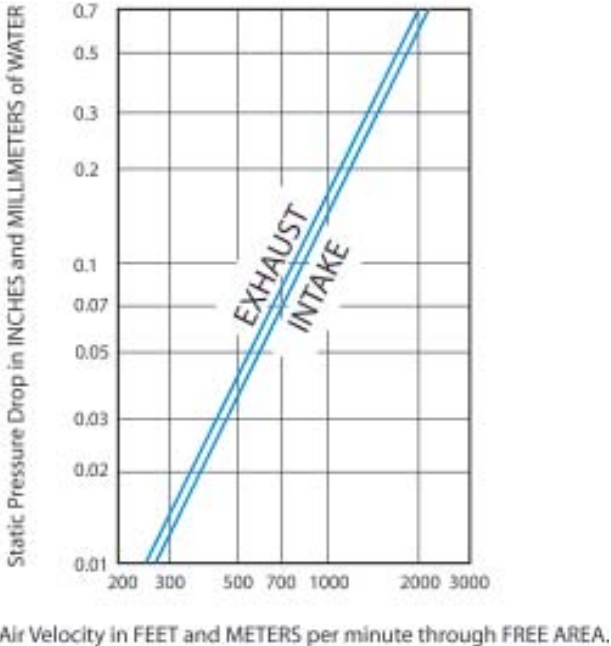

Free Area in Square Feet

Height (inches)	Width (inches)												
	12	18	24	30	38	42	48	54	60	66	72	84	96
12	0.364	0.559	0.754	0.949	1.157	1.313	1.521	1.716	1.911	2.106	2.314	2.678	3.068
	36%	37%	38%	38%	37%	38%	38%	38%	38%	38%	39%	38%	38%
18	0.663	1.014	1.378	1.742	2.106	2.405	2.769	3.133	3.497	3.861	4.225	4.888	5.603
	44%	45%	46%	46%	44%	46%	46%	46%	47%	47%	47%	47%	47%
24	0.871	1.352	1.833	2.314	2.795	3.198	3.679	4.16	4.641	5.122	5.603	6.487	7.436
	44%	45%	46%	46%	44%	46%	46%	46%	46%	47%	47%	46%	46%
30	1.157	1.807	2.444	3.081	3.718	4.251	4.901	5.538	6.175	6.812	7.462	8.632	9.906
	46%	48%	49%	49%	47%	49%	49%	49%	49%	50%	50%	49%	50%
38	1.404	2.184	2.964	3.744	4.511	5.161	5.941	6.721	7.501	8.268	9.048	10.478	12.025
	44%	46%	47%	47%	45%	47%	47%	47%	47%	47%	48%	47%	47%
42	1.651	2.561	3.471	4.381	5.291	6.045	6.955	7.865	8.775	9.685	10.595	12.259	14.079
	47%	49%	50%	50%	48%	49%	50%	50%	50%	50%	50%	50%	50%
48	1.95	3.016	4.095	5.161	6.24	7.137	8.203	9.282	10.348	11.427	12.506	14.469	16.614
	49%	50%	51%	52%	49%	51%	51%	52%	52%	52%	52%	52%	52%
54	2.158	3.354	4.55	5.733	6.929	7.917	9.113	10.309	11.492	12.688	13.884	16.068	18.447
	48%	50%	51%	51%	49%	50%	51%	51%	51%	51%	51%	51%	51%
60	2.444	3.796	5.148	6.5	7.852	8.983	10.335	11.687	13.039	14.391	15.73	18.213	20.917
	49%	51%	51%	52%	50%	51%	52%	52%	52%	52%	52%	52%	52%
66	2.704	4.186	5.668	7.163	8.645	9.763	11.375	12.87	14.352	15.847	17.329	20.059	23.036
	49%	51%	52%	52%	50%	51%	52%	52%	52%	52%	53%	52%	52%
72	2.938	4.563	6.175	7.8	9.425	10.764	12.389	14.014	13.026	17.251	18.876	21.84	25.077
	49%	51%	51%	52%	50%	51%	52%	52%	43%	52%	52%	52%	52%
78	3.237	5.018	6.799	8.593	10.374	11.856	13.637	15.431	17.212	18.993	20.774	24.05	27.625
	50%	51%	52%	53%	50%	52%	52%	53%	53%	53%	53%	53%	53%
84	3.445	5.356	7.254	9.152	11.063	12.649	14.547	16.328	18.356	20.254	22.165	25.649	29.328
	49%	51%	52%	52%	50%	52%	52%	52%	52%	53%	53%	52%	52%
90	3.744	5.798	7.865	9.919	11.986	13.702	15.769	17.836	19.89	21.957	24.011	27.794	31.915
	50%	52%	52%	53%	50%	52%	53%	53%	53%	53%	53%	53%	53%
96	3.991	6.188	8.385	10.582	12.779	14.612	16.809	19.019	21.216	23.413	25.61	29.64	34.034
	50%	52%	52%	53%	50%	52%	53%	53%	53%	53%	53%	53%	53%
108	4.524	7.02	9.516	12.012	14.508	16.588	19.084	21.58	24.076	26.559	29.055	33.631	38.623
	50%	52%	53%	53%	51%	53%	53%	53%	54%	54%	54%	53%	54%
120	5.031	7.8	10.569	13.351	16.12	18.434	21.203	23.972	26.754	29.523	32.292	37.375	42.926
	50%	52%	53%	53%	51%	53%	53%	53%	54%	54%	54%	53%	54%

Rain Proof Aluminum Louver

Model : RAL



Fig.1 shows Model RAL

Product Features

Komfort Flow Rain Proof Aluminium Louver is an extruded aluminum stationary louver designed to protect air intake and exhaust openings in building exterior walls that are sensitive to the penetration of wind driven rain.

Design incorporates drainable head member and horizontal blades to provide maximum resistance to wind blown rain.

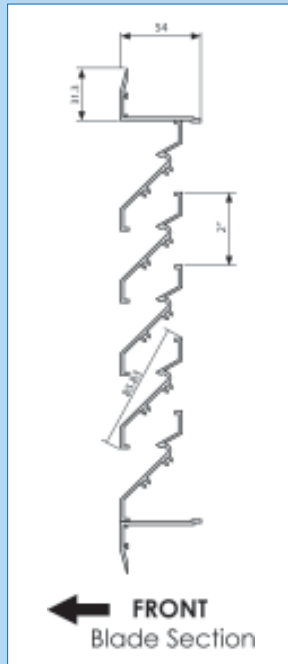

Fig.2 shows Blade Section

Application of any louver involves selecting an airflow velocity through the louver free area (free area velocity in fpm) that produces an acceptable pressure drop and for intake applications minimizes carry through of normally encountered rain water.

The point of zero water penetration is defined as that velocity where the water penetration curve projects through .01 oz. of water (penetration) per sq.ft. of louver free area.

The beginning point of water penetration for Model RAL is 514 FPM free area velocity. These performance ratings do not guarantee a louver to be weatherproof or stormproof and should be used in combination with other factors in selecting louvers (i.e. prevailing wind direction, weather patterns for the building location area, desired safety factor, etc.).

Water Penetration Throught A48" x 48" Louver for 15 Min. Test at 4"/Hr. Rainfall

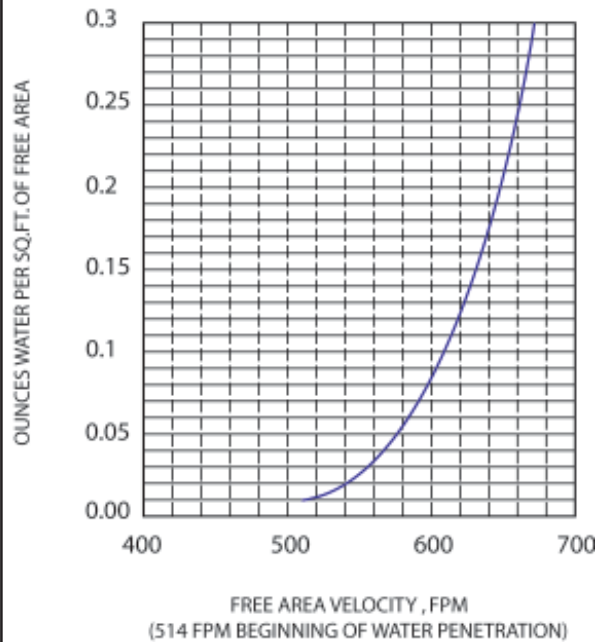

Louver Pressure Drop

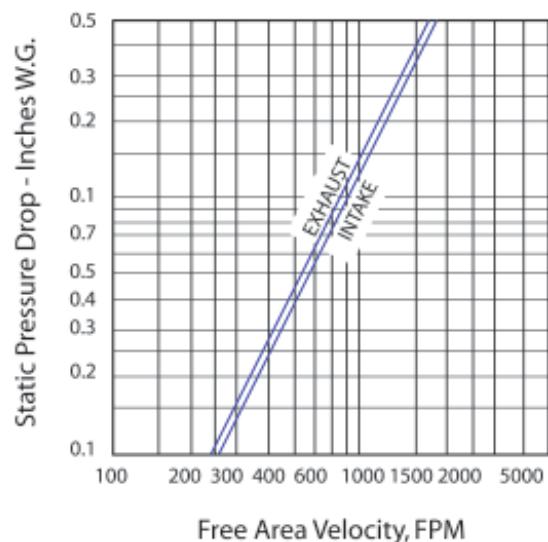

Free Area in Square Feet

Height (inches)	Width (inches)												
	12	18	24	30	38	42	48	54	60	66	72	84	96
12	0.28	0.43	0.58	0.73	0.89	1.01	1.17	1.32	1.47	1.62	1.78	2.06	2.36
	28%	29%	29%	29%	28%	29%	29%	29%	29%	29%	30%	29%	30%
18	0.51	0.78	1.06	1.34	1.62	1.85	2.13	2.41	2.69	2.97	3.25	3.76	4.31
	34%	35%	35%	36%	34%	35%	36%	36%	36%	36%	36%	36%	36%
24	0.67	1.04	1.41	1.78	2.15	2.46	2.83	3.2	3.57	3.94	4.31	4.99	5.72
	34%	35%	35%	36%	34%	35%	35%	36%	36%	36%	36%	36%	36%
30	0.89	1.39	1.88	2.37	2.86	3.27	3.77	4.26	4.75	5.24	5.74	6.64	7.62
	36%	37%	38%	38%	36%	37%	38%	38%	38%	38%	38%	38%	38%
38	1.08	1.68	2.28	2.88	3.47	3.97	4.57	5.17	5.77	6.36	6.96	8.06	9.25
	34%	35%	36%	36%	35%	36%	36%	36%	36%	37%	37%	36%	37%
42	1.27	1.97	2.67	3.37	4.07	4.65	5.35	6.05	6.75	7.45	8.15	9.43	10.83
	36%	38%	38%	39%	37%	38%	38%	38%	39%	39%	39%	38%	39%
48	1.5	2.32	3.15	3.97	4.8	5.49	6.31	7.14	7.96	8.79	9.62	11.13	12.78
	38%	39%	39%	40%	38%	39%	39%	40%	40%	40%	40%	40%	40%
54	1.66	2.58	3.5	4.41	5.33	6.09	7.01	7.93	8.84	9.76	10.68	12.36	14.19
	37%	38%	39%	39%	37%	39%	39%	39%	39%	39%	40%	39%	39%
60	1.88	2.92	3.96	5	6.04	6.91	7.95	8.99	10.03	11.07	12.1	14.01	16.09
	38%	39%	40%	40%	38%	39%	40%	40%	40%	40%	40%	40%	40%
66	2.08	3.22	4.36	5.51	6.65	7.51	8.75	9.9	11.04	12.19	13.33	15.43	17.72
	38%	39%	40%	40%	38%	39%	40%	40%	40%	40%	40%	40%	40%
72	2.26	3.51	4.75	6	7.25	8.28	9.53	10.78	10.02	13.27	14.52	16.8	19.29
	38%	39%	40%	40%	38%	39%	40%	40%	33%	40%	40%	40%	40%
78	2.49	3.86	5.23	6.61	7.98	9.12	10.49	11.87	13.24	14.61	15.98	18.5	21.25
	38%	40%	40%	41%	39%	40%	40%	41%	41%	41%	41%	41%	41%
84	2.65	4.12	5.58	7.04	8.51	9.73	11.19	12.56	14.12	15.58	17.05	19.73	22.56
	38%	39%	40%	40%	38%	40%	40%	40%	40%	40%	41%	40%	40%
90	2.88	4.46	6.05	7.63	9.22	10.54	12.13	13.72	15.3	16.89	18.47	21.38	24.55
	38%	40%	40%	41%	39%	40%	40%	41%	41%	41%	41%	41%	41%
96	3.07	4.76	6.45	8.14	9.83	11.24	12.93	14.63	16.32	18.01	19.7	22.8	26.18
	38%	40%	40%	41%	39%	40%	40%	41%	41%	41%	41%	41%	41%
108	3.48	5.4	7.32	9.24	11.16	12.76	14.68	16.6	18.52	20.43	22.35	25.87	29.71
	39%	40%	41%	41%	39%	41%	41%	41%	41%	41%	41%	41%	41%
120	3.87	6	8.13	10.27	12.4	14.18	16.31	18.44	20.58	22.71	24.84	28.75	33.02
	39%	40%	41%	41%	39%	41%	41%	41%	41%	41%	41%	41%	41%

Diffuser Damper **Model : WD**

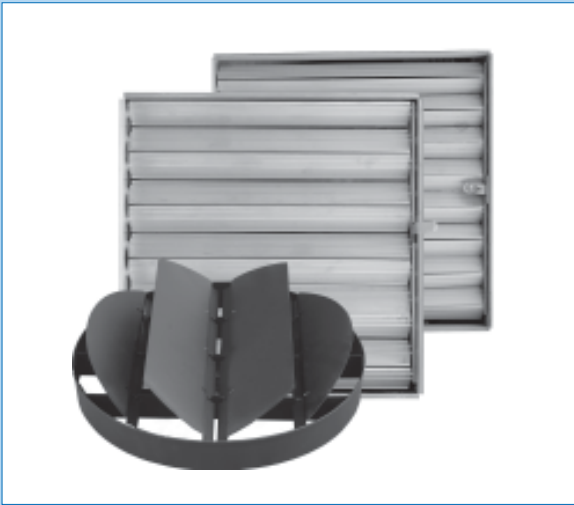

Fig.1 shows Diffuser Damper

Product Features

Diffuser Damper are designed to install on most of our grilles. Volume control louvers move simultaneously in opposite directions closing to provide superior metering and control with a minimum disturbance of the air pattern.

Material

Komfort Flow Diffuser Damper is made of Extruded Aluminum Frame and Blade.

This is available in two operators:

- Lever (Standard operator)
- Screw (Optional operator)

LEVER TYPE - Standard

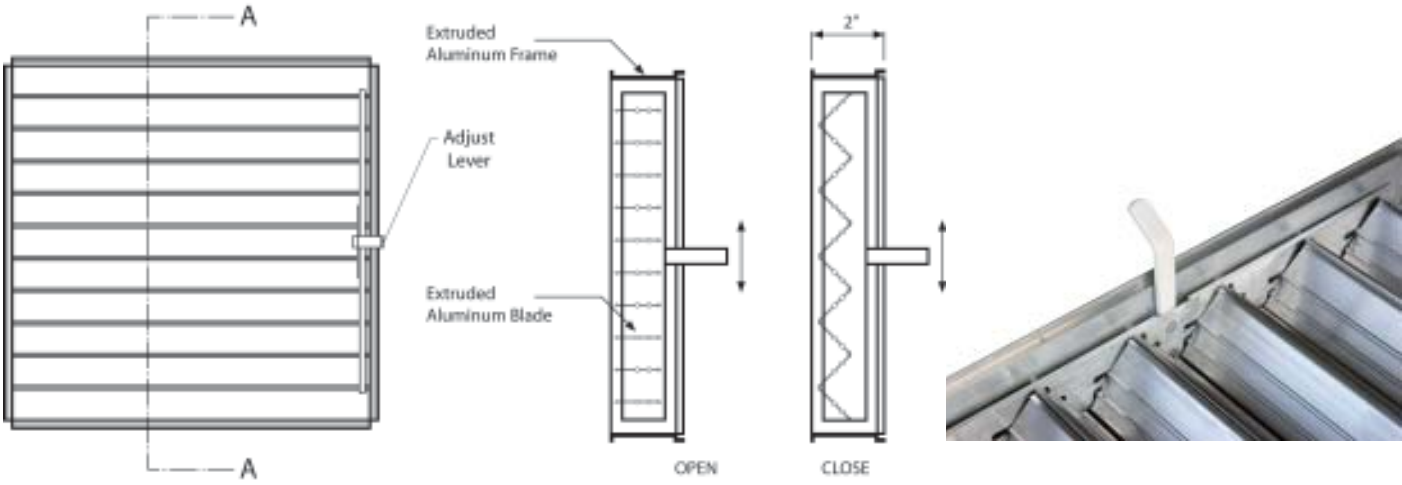

SCREW TYPE - Optional

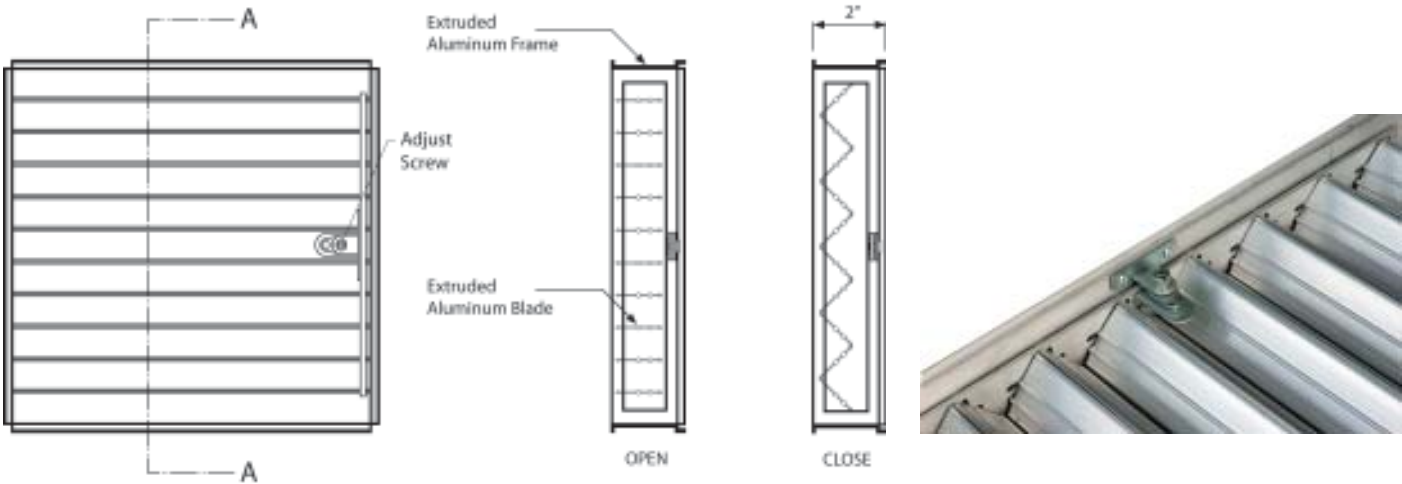

Butterfly Damper **Model : BD**



Fig.1 shows Butterfly Damper

Product Features

Butterfly Damper is a damper for volume control in round neck diffusers. Continuously adjustable. Friction pivots hold the heavy gauge blades at the desired setting.

Quickly , easily adjuste from the face side of the diffuser. Can be mounted directly on the diffusers neck before installation.

Not recommended for use with flexible duct.

Material

Komfort Flow Diffuser Damper is made of Galvanized Steel. Black paint (Optional)

SECTION

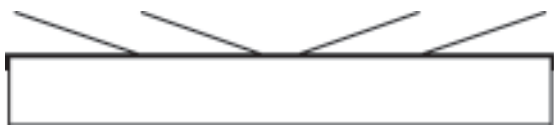

Round Diffuser

Jet Diffuser



Opened



Closed

Butterfly Damper is designed to install with Komfort Flow Round Diffuser (Model "RD") and Komfort Flow Jet Diffuser (Model "Jet")

Galvanized Steel Duct Damper **Model : VD**



Fig.1 shows Model VD

Product Features

A basic no-frills industrial Triple-V Groove Damper, Model VD is a ruggedly built, solid performer in Komfort Flow's line of heavy duty control dampers.

Material

The frame size is 6" deep x 1-3/8" x 16 gage (150 x 35 x 1.6 mm.) galvanized steel channel. Blades is triple-V groove, 16 gage (1.6mm) galvanized steel. Axles shall be 10 mm plated steel rod. The axles shall be an integral part of the damper linkage attaching directly to the tie bar. Bearings is brass.

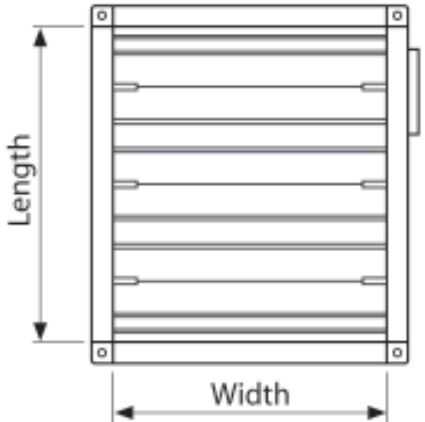

Parallel Blade Damper Type

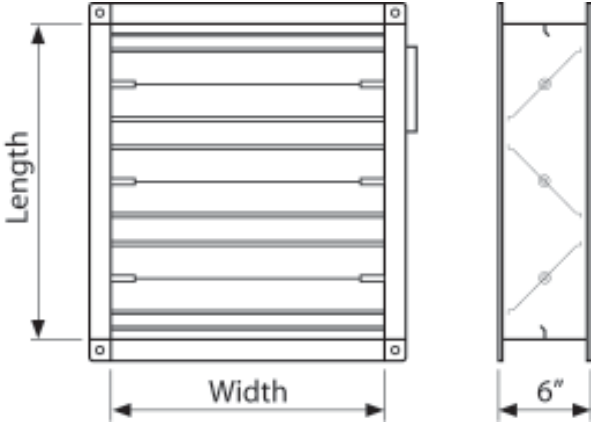

Opposed Blade Damper Type

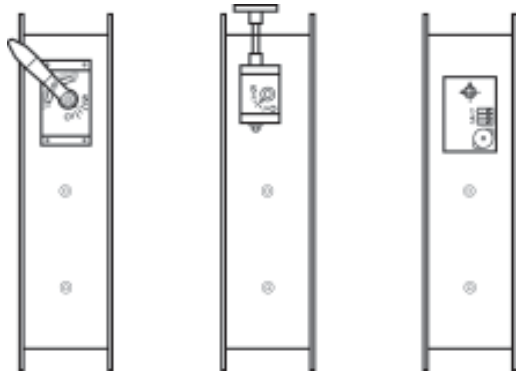

Lever Hand Gear Motorized

Komfort Flow Duct Damper offer the selection of

- Parallel Blade Damper (called "Model VD")
- Opposed Blade Damper (called "Model VD-O")

With the three options of Adjust equipment as follows

- Hand Gear (called "Model XX-X - **G**")
- Lever (called "Model XX-X - **L**")
- Motorized (called "Model XX-X - **M**")

Performance Data

Air Leakage - Damper Closed (45" x 48")

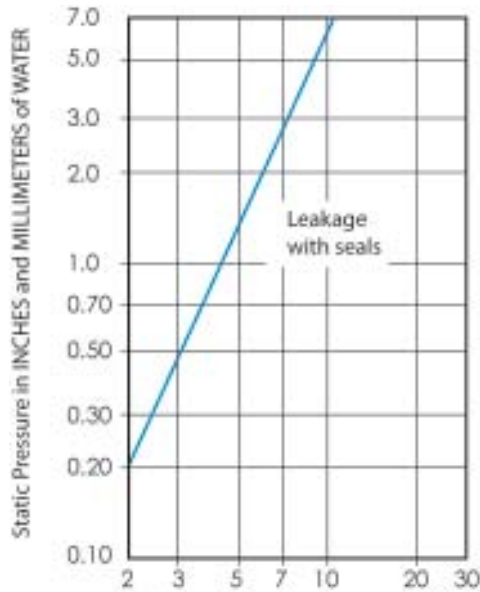

Pressure Drop - Damper Open (45" x 48")

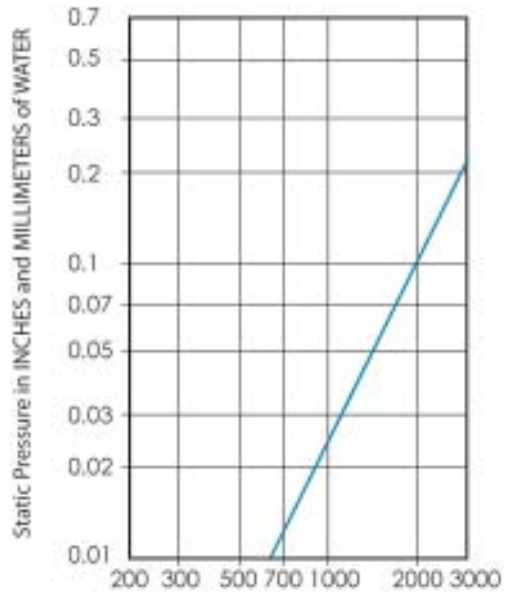

Damper Width Inches	Maximum System Pressure	Maximum System Velocity	Leakage	
			Percent of Max. Flow	CFM/Sq.Ft.
48"	7.00 in.wg.	3500 FPM	0.92	32.0
36"	9.00 in.wg.	3500 FPM	0.92	32.0
24"	15.50 in.wg.	3500 FPM	1.15	40.0
12"	20.00 in.wg.	3500 FPM	1.72	60.0

SPECIFICATION

BLADE MATERIAL (NOM.)	6" (152) wide
	16 gage (1.6) galvanized steel
FRAME MATERIAL (NOM.)	6" x 1-3/8" (152 x 35 x 1.6 mm.)
	16 gage (1.6) galvanized steel
LINKAGE	Concealed in frame
AXLES	Dia. 10 mm.
	plated steel
BEARINGS	Brass
SEALS	Polyurethane foam on blade,
	flex. Metal jamb (optional)
CONTROL	Lever (standard)
	Hand Gear (Optional)
	Motorized (Optional)
MINIMUM SIZE	Single Blade
	4" x 4" (100 x 100)
MAXIMUM SIZE	Single section
	48" x 72" (1219 x 1829)
	Multiple section size - unlimited

Air Filter

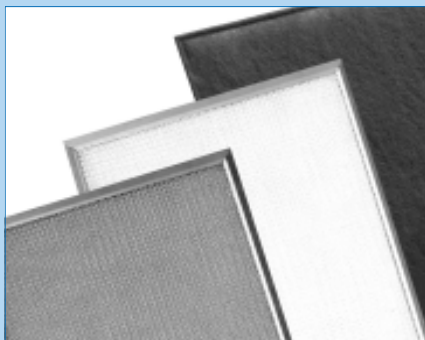

Fig.1 shows all kinds of Air Filter

Product Features

Filters are primarily used to remove particles from the air. The type and design of filter determine the efficiency at removing particles of a given size and the amount of energy needed to pull or push air through the filter.

Filters are rated by different standards and test methods such as dust spot and arrestance which measuredifferent aspects of performance.

Our company offers three mains selection of Komfort Flow Air Filter : Aluminium Filter, Synthetic Filter and Nylon Filter.



ALUMINIUM FILTER

Komfort Flow Aluminium Filter is made from several layer of Expaned Aluminium Sheets. This can filter dirt, dust, oil .

Velocity (FPM) Resistance (W.G.)

300	0.05
350	0.06
400	0.08
450	0.10
500	0.13

Material : Aluminium Sheets
 Washable : YES
 Standard : 1.5" - 2"
 Thickness
Special size is upon request.



SYNTHETIC FILTER - AIR FILTER MEDIA - White Color

Prefilters for high dust concentrations. Air ventilation and air conditioning plants with low requirements for air quality.

Technical Data

Nominal air volume	5400 m ³ /h/m ²
Average dust weight arrestance	82 %
Average dust spot efficiency	- %
Initial pressure drop	19 Pa
Recommended final pressure drop	160 Pa
Temp. resistance Max.	120 °C

Material : Synthetic
 Washable : YES
 Standard : 1.5" - 2"
 Thickness
Special size is upon request.



SYNTHETIC FILER - AIR FILTER MEDIA - Black Color

Prefilters for high dust concentrations. Air ventilation and air conditioning plants with low requirements for air quality. Material is synthetic fiber in Black Color, Size and Thickness as customer's order.

Technical Data

Nominal air volume	5400 m ³ /h/m ²
Average dust weight arrestance	82 %
Average dust spot efficiency	- %
Initial pressure drop	19 Pa
Recommended final pressure drop	160 Pa
Temp. resistance Max.	130 °C

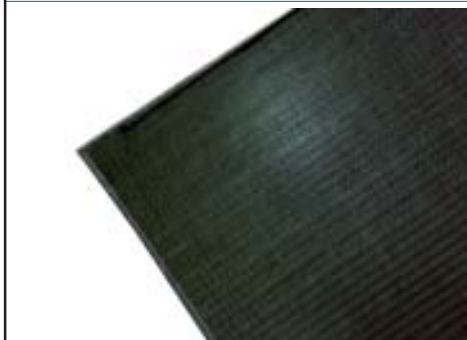
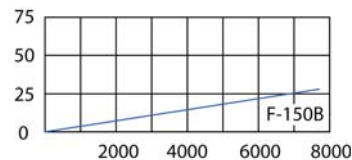

NYLON FILTER

Komfort Flow Nylon Filter can filter dust in long time due to durable and strong plastic net. It comes in many small square-shape holes originate good ventilation. This type of filter is Easy to clean by using brush

Technical Data

Average synthetic dust weight arrestance	80 %
Initial pressure drop	23 Pa
Recommended final pressure drop	120 Pa
Maximum Ambient Temperature	100 °C
Material	PP Thread Size 0.20-0.21 mm.



CENTRALWORLD SHOPPING COMPLEX



MRTA STATION , THAILAND



ZEN DEPARTMENT STORE



THAI AIRWAYS CATERING



THAI AIRWAYS GROUND SERVICE

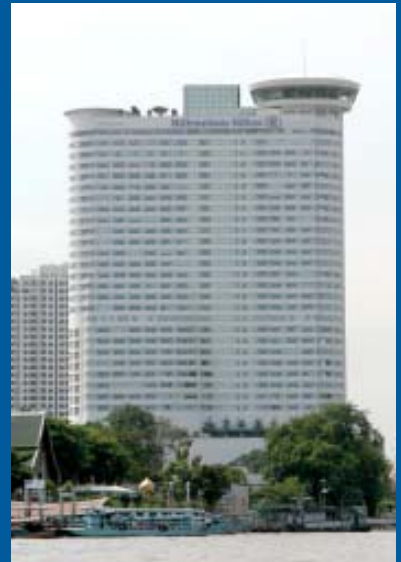

MILLENNIUM HILTON HOTEL



HOLIDAY INN HOTEL



SEACON SQUARE



SIAM PARAGON



INTERCONTINENTAL



GRAND HYATT ERAWAN



MBK CENTER

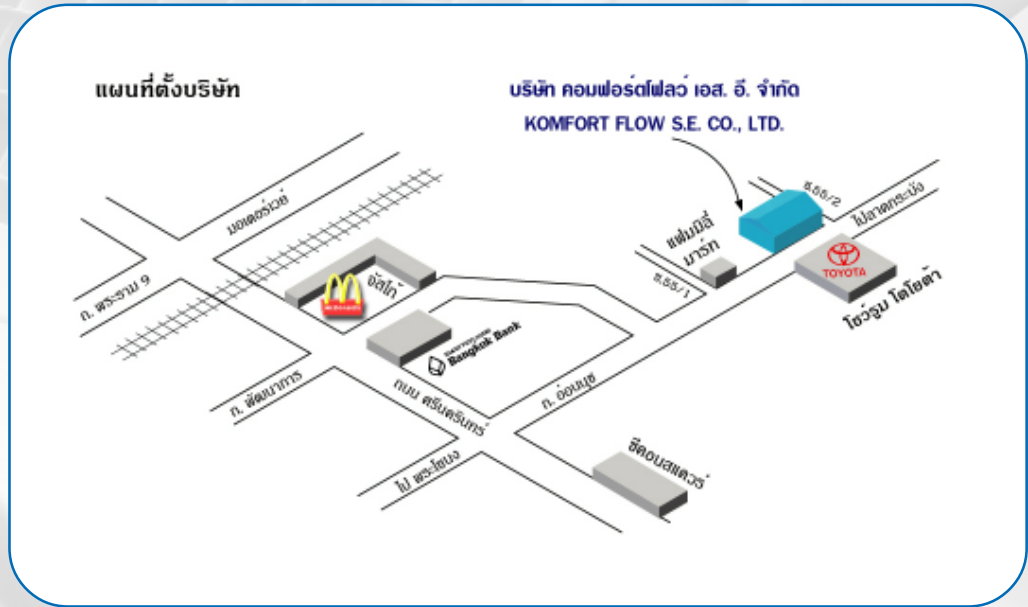

Komfort Flow S.E. Co., Ltd.

367 ถนนอ่อนนุช แขวงประเวศ เขตประเวศ กทม. 10250
Tel : 0-2321-2592, 0-2321-2511, 0-2321-4154
Fax: 0-2321-5204
Url: www.komfortflow.com

Komfort Flow S.E. Co., Ltd.

367 Onnut Rd. Pravet Bangkok 10250, Thailand
Tel : 0-2321-2592, 0-2321-2511, 0-2321-4154
Fax: 0-2321-5204
Url: www.komfortflow.com